

Tolerances for backing flanges and flow liners on basis of DIN EN 1092-1

Nominal size over	up to	D ₂₁	D ₂₃	D ₂₂	D ₂₀			S ₂₁		
					<= 26	<= 48	> 48	<= 18	<= 48	> 48
	500	± 3	± 3	± 1						
500	1200	± 5	± 5	± 1,5	+ 1,5	+ 2,5	+ 4	± 1	± 1,5	± 2
1200	1800	± 7	± 7							
1800		± 10	± 10	± 2						

Tolerances for rubber parts on basis of FSA-Technical Handbook *

Nominal size over	up to	D ₁ *	D ₃ *	D ₂ *	D ₀₁	LF Fabrication length *				S ₁			Alignment of holes	
						<= 150	<= 300	<= 600	> 600	<= 10	<= 15	> 15	LF <= 350	LF > 350
	550	± 5	± 6	± 5	± 2	± 5		± 1 %		± 2	± 3	± 4	± 3	± 5
550	1150	± 10	± 13											
1150	1750	+ 10 / - 12	+ 19 / - 13	± 6										
1750		+ 10 / - 16	+ 25 / - 14			± 6	± 10	± 1,5 %						

The copying, distribution and utilization of this documents as well as the communication of its contents to others without expressed authorization is prohibited. Offenders will be held liable for the payment of damages.

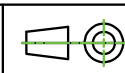

Scale	Tolerances	Size
	QMV-15	A3

Expansion Joint
Reference no.:
Drawing no.:

ditec® ditec Dichtungstechnik GmbH
 D-97318 Kitzingen
 Tel. +49(0)9321/23070
 www.ditec-adam.de

1 / 1
 Page

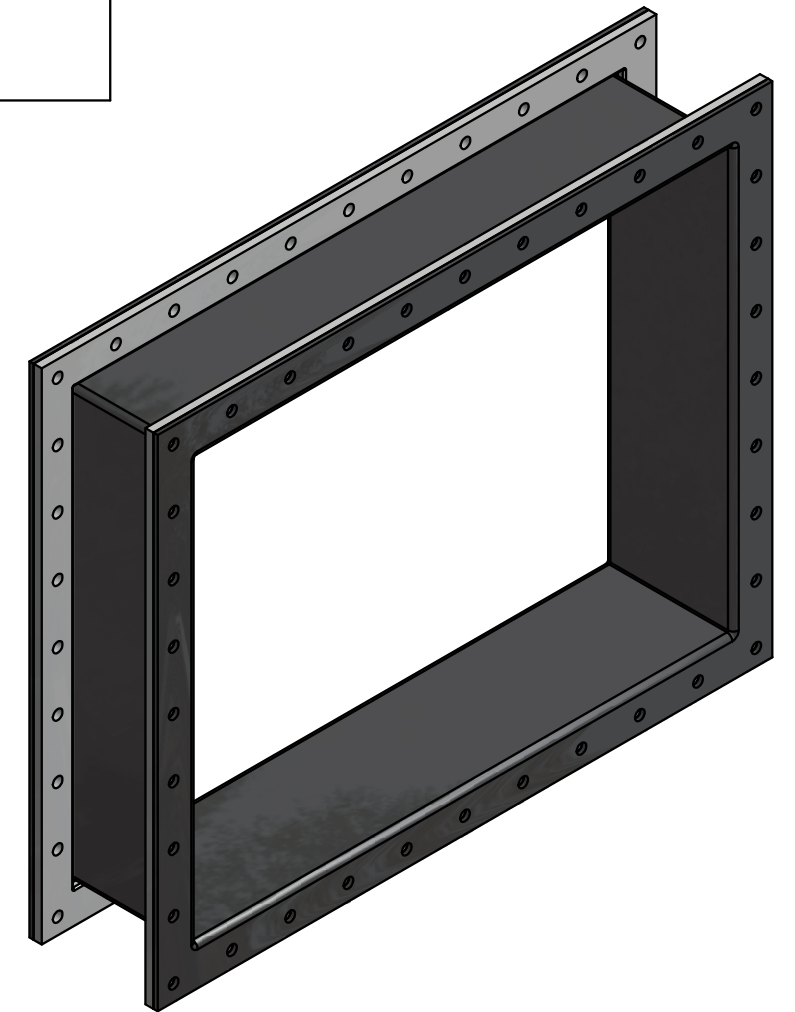
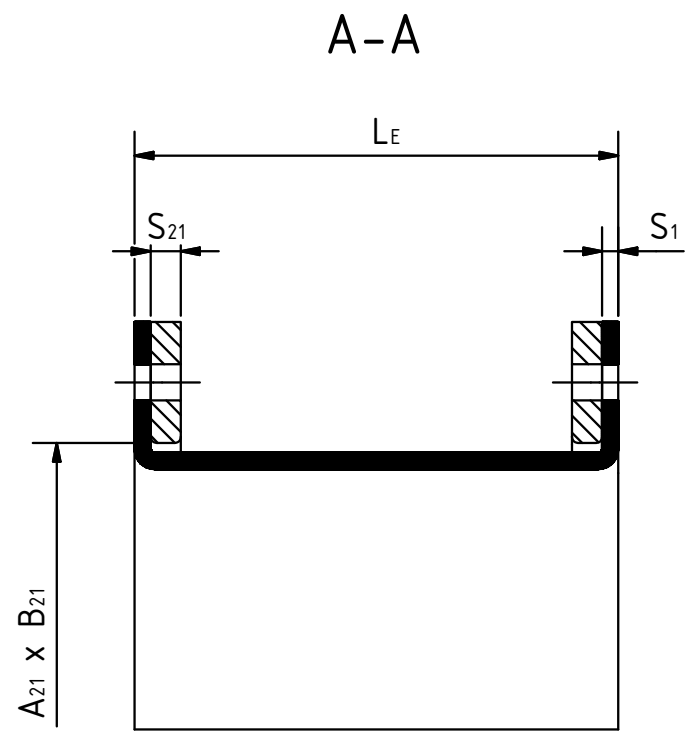
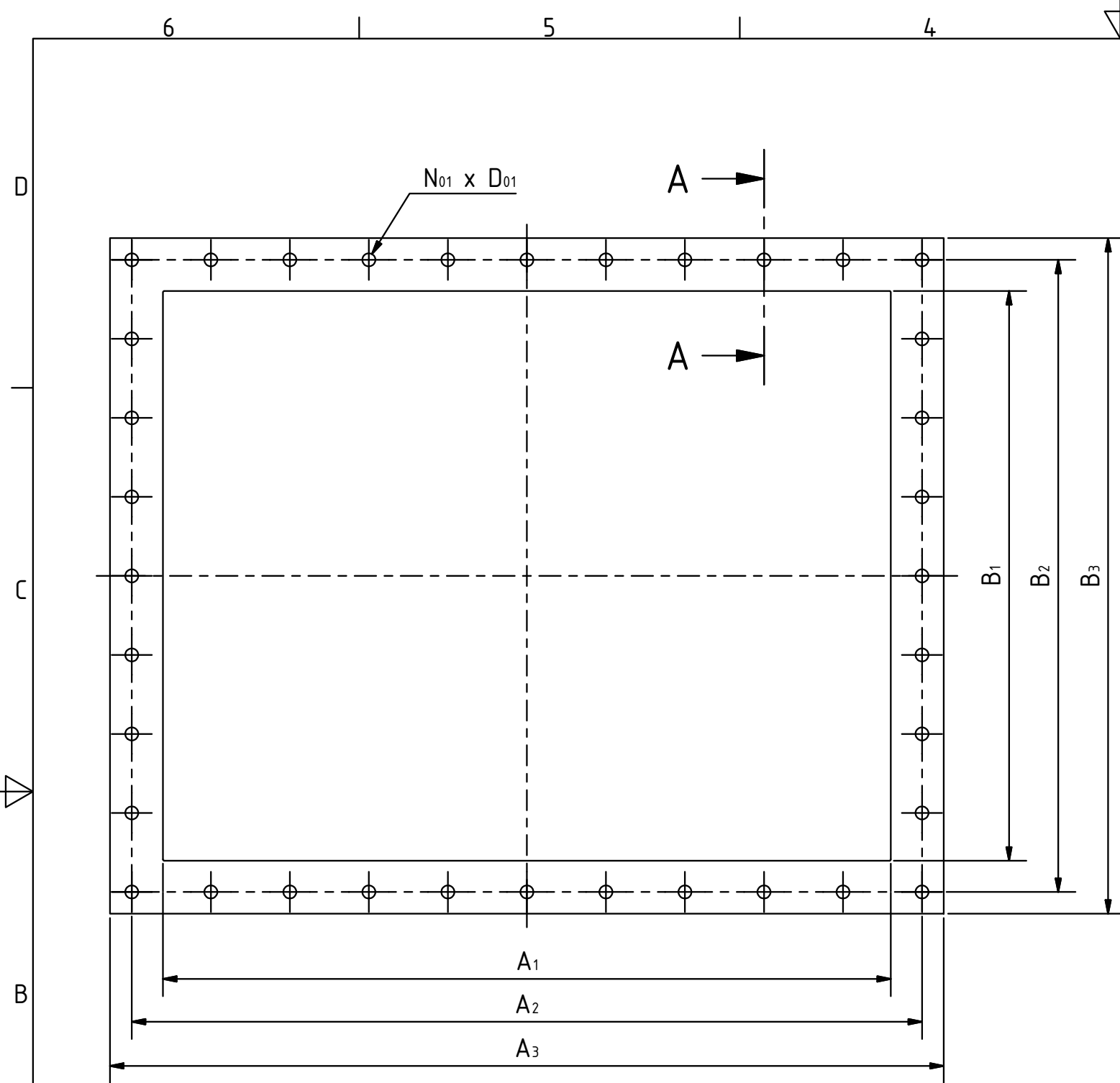

Tolerances for backing flanges and flow liners on basis of DIN EN 1092-1

Nominal size over	up to	D ₂₁	D ₂₃	D ₂₂	D ₂₀			S ₂₁		
					<= 26	<= 48	> 48	<= 18	<= 48	> 48
	500	± 3	± 3	± 1						
500	1200	± 5	± 5	± 1,5	+ 1,5	+ 2,5	+ 4	± 1	± 1,5	± 2
1200	1800	± 7	± 7							
1800		± 10	± 10	± 2						

Tolerances for rubber parts on basis of FSA-Technical Handbook *

Nominal size over	up to	D ₁ *	D ₃ *	D ₂ *	D ₀₁	LF Fabrication length *				S ₁			Alignment of holes	
						<= 150	<= 300	<= 600	> 600	<= 10	<= 15	> 15	LF <= 350	LF > 350
	550	± 5	± 6	± 5	± 2	± 5		± 1 %				± 3	± 5	
550	1150	± 10	± 13											
1150	1750	+ 10 / - 12	+ 19 / - 13	± 6	± 2	± 6	± 10	± 1,5 %		± 2	± 3	± 4	± 4	± 6
1750		+ 10 / - 16	+ 25 / - 14											

The copying, distribution and utilization of this documents as well as the communication of its contents to others without expressed authorization is prohibited. Offenders will be held liable for the payment of damages.

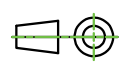

Scale	Tolerances	Size
	QMV-15	A3

Expansion Joint

ditec® ditec Dichtungstechnik GmbH
 D-97318 Kitzingen
 Tel. +49(0)9321/23070
 www.ditec-adam.de

Reference no.:
 Drawing no.: 1 / 1
 Page