

Tolerances for backing flanges and flow liners on basis of DIN EN 1092-1

| Nominal size over | up to | D ₂₁ | D ₂₃ | D ₂₂ | D ₂₀ | | | S ₂₁ | | |
|-------------------|-------|-----------------|-----------------|-----------------|-----------------|-------|------|-----------------|-------|------|
| | | | | | <= 26 | <= 48 | > 48 | <= 18 | <= 48 | > 48 |
| | 500 | ± 3 | ± 3 | ± 1 | | | | | | |
| 500 | 1200 | ± 5 | ± 5 | ± 1,5 | + 1,5 | + 2,5 | + 4 | ± 1 | ± 1,5 | ± 2 |
| 1200 | 1800 | ± 7 | ± 7 | | | | | | | |
| 1800 | | ± 10 | ± 10 | ± 2 | | | | | | |

Tolerances for rubber parts on basis of FSA-Technical Handbook *

| Nominal size over | up to | D ₁ * | D ₃ * | D ₂ * | D ₀₁ | LF Fabrication length * | | | | S ₁ | | | Alignment of holes | |
|-------------------|-------|------------------|------------------|------------------|-----------------|-------------------------|--------|---------|-------|----------------|-------|------|--------------------|----------|
| | | | | | | <= 150 | <= 300 | <= 600 | > 600 | <= 10 | <= 15 | > 15 | LF <= 350 | LF > 350 |
| | 550 | ± 5 | ± 6 | ± 5 | ± 2 | ± 5 | | ± 1 % | | | | | ± 3 | ± 5 |
| 550 | 1150 | ± 10 | ± 13 | | | | | | | | | | | |
| 1150 | 1750 | + 10 / - 12 | + 19 / - 13 | ± 6 | | | | | | ± 2 | ± 3 | ± 4 | | |
| 1750 | | + 10 / - 16 | + 25 / - 14 | | | ± 6 | ± 10 | ± 1,5 % | | | | | ± 4 | ± 6 |

The copying, distribution and utilization of this documents as well as the communication of its contents to others without expressed authorization is prohibited. Offenders will be held liable for the payment of damages.

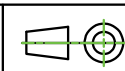

| Scale | Tolerances | Size |
|-------|------------|------|
| | QMV-15 | A3 |

**Expansion Joint
GU100**



| | |
|----------------|-------|
| Reference no.: | |
| Drawing no.: | 1 / 1 |
| | Page |

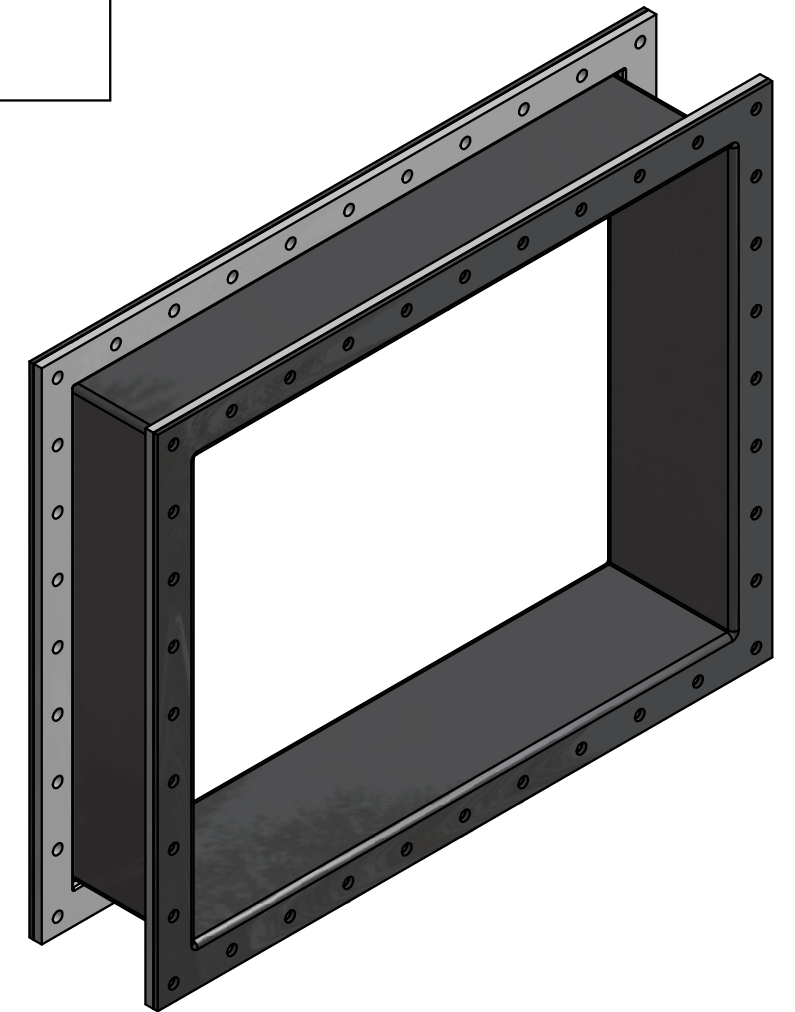
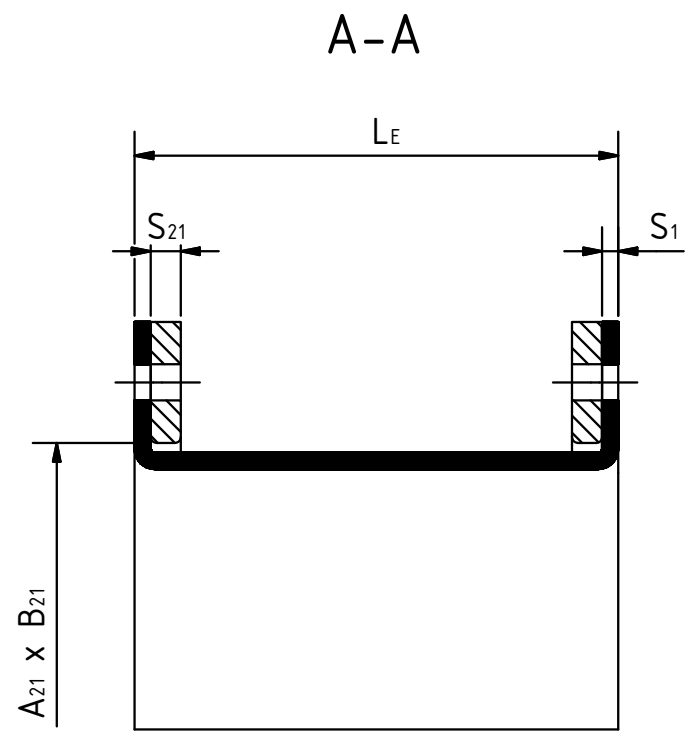
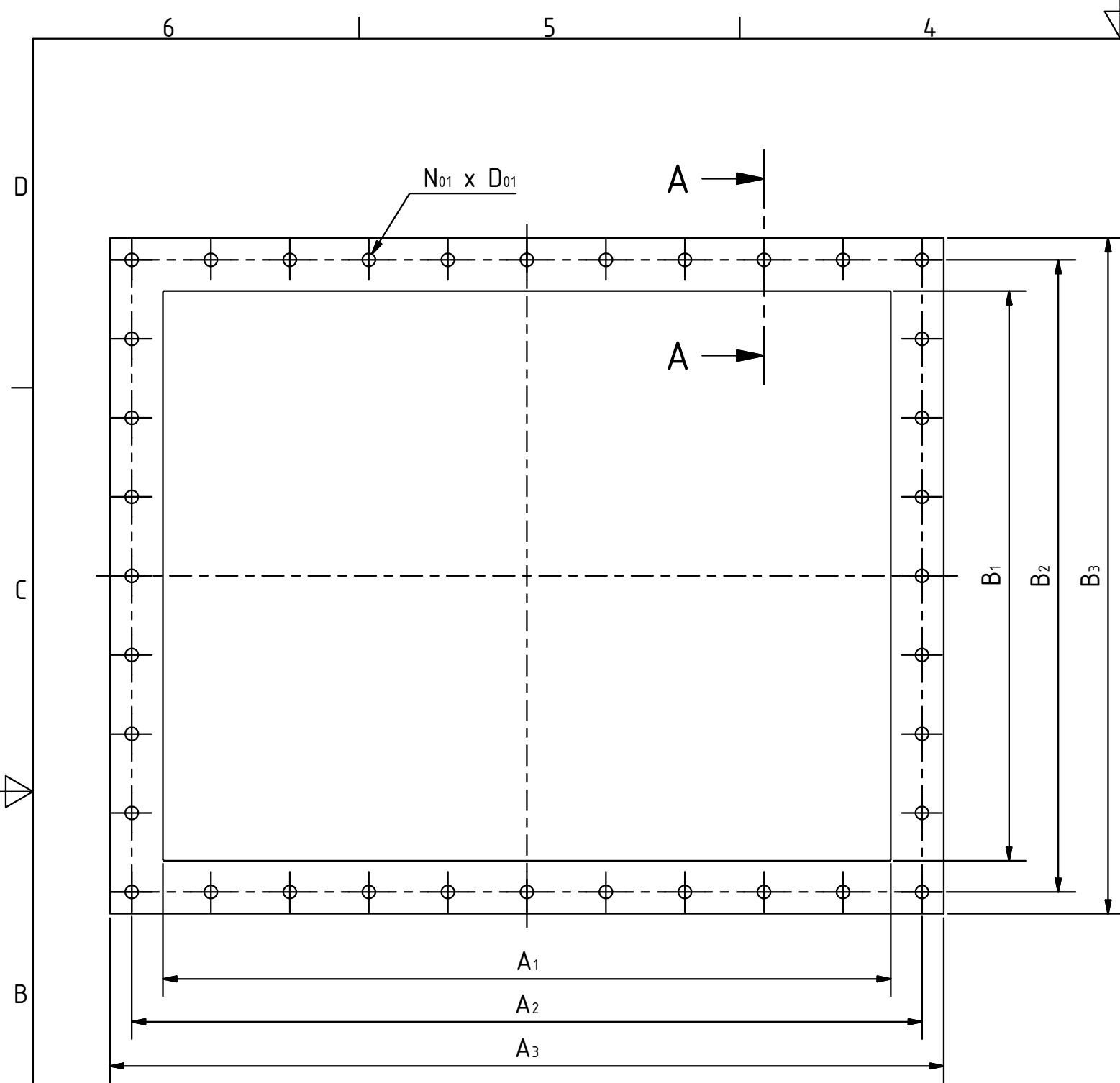

Tolerances for backing flanges and flow liners on basis of DIN EN 1092-1

| Nominal size over | up to | D ₂₁ | D ₂₃ | D ₂₂ | D ₂₀ | | | S ₂₁ | | |
|-------------------|-------|-----------------|-----------------|-----------------|-----------------|-------|------|-----------------|-------|------|
| | | | | | <= 26 | <= 48 | > 48 | <= 18 | <= 48 | > 48 |
| | 500 | ± 3 | ± 3 | ± 1 | | | | | | |
| 500 | 1200 | ± 5 | ± 5 | ± 1,5 | + 1,5 | + 2,5 | + 4 | ± 1 | ± 1,5 | ± 2 |
| 1200 | 1800 | ± 7 | ± 7 | | | | | | | |
| 1800 | | ± 10 | ± 10 | ± 2 | | | | | | |

Tolerances for rubber parts on basis of FSA-Technical Handbook *

| Nominal size over | up to | D ₁ * | D ₃ * | D ₂ * | D ₀₁ | LF Fabrication length * | | | | S ₁ | | | Alignment of holes | |
|-------------------|-------|------------------|------------------|------------------|-----------------|-------------------------|--------|---------|-------|----------------|-------|------|--------------------|----------|
| | | | | | | <= 150 | <= 300 | <= 600 | > 600 | <= 10 | <= 15 | > 15 | LF <= 350 | LF > 350 |
| | 550 | ± 5 | ± 6 | ± 5 | ± 2 | ± 5 | | ± 1 % | | | | ± 3 | ± 5 | |
| 550 | 1150 | ± 10 | ± 13 | | | | | | | | | | | |
| 1150 | 1750 | + 10 / - 12 | + 19 / - 13 | ± 6 | ± 2 | ± 6 | ± 10 | ± 1,5 % | ± 2 | ± 3 | ± 4 | ± 4 | ± 6 | |
| 1750 | | + 10 / - 16 | + 25 / - 14 | | | | | | | | | | | |

The copying, distribution and utilization of this documents as well as the communication of its contents to others without expressed authorization is prohibited. Offenders will be held liable for the payment of damages.

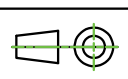

| | | |
|-------|------------|------|
| Scale | Tolerances | Size |
| | QMV-15 | A3 |

Expansion Joint
GU100



| | |
|----------------|-------|
| Reference no.: | |
| Drawing no.: | 1 / 1 |
| | Page |